

REVO MICRO INGROUND



The Revo Micro Inground is a versatile, sustainable lighting fixture that can be configured to suit a variety of needs. Its high light output, interchangeable optics and compact design make it ideal for a wide range of applications, while its ventilated Gore-Tex membrane help prevent condensation and ensure long-term performance. With more than 100 different configurations, there is always a Revo Micro that suits your needs.

Categories: [Revo Inground Series](#), [Outdoor](#), [Inground](#), [Architainment](#), [Automotive Showrooms](#)

> Specifications

Type	Revo Micro Inground, Outdoor inground
Colour	Die cast housing + anti corrosion housing: black
Material	Marine grade 316 stainless steel mounting ring. Stainless steel 316 mounting screws. ABS plastic corrosion housing
Weight	900 gram
Mounting hole	10 cm
Installation depth	13,5 cm
Pressure	15 kg/cm ²
Ambient temperature	-10°C till 40°C

Optics	20° 30° 66° 20 x 42°
Light source	High Power LED
Light output	450 lumen
CRI	80
LED colours	2200K 2700K 3000K 4000K amber

Power consumption	Max. 5 Watt
Power supply	100-240 VAC 12-24 AC/DC
Connection	cable with open end
Cable length	200 cm

IK-class	IK10
IP rating	IP 67
Protection class	3
Certifications	CE

Energy label A

Lifetime 50.000 hours
LB Value L90B10 at 50.000h
Warranty 3 years

Remarks Ventilation gland with Gore-Tex membrane fitted to avoid moisture and condensation. IP67 2/3/4 way gel mold set included in the package

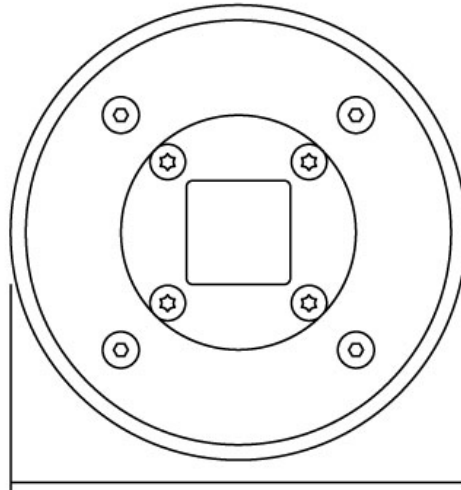

ø 110 mm

